

HOLE PUNCH LINDOVA H4

SEE OUR ENTIRE PRODUCT RANGE AT: WWW.LINDOVA.SE

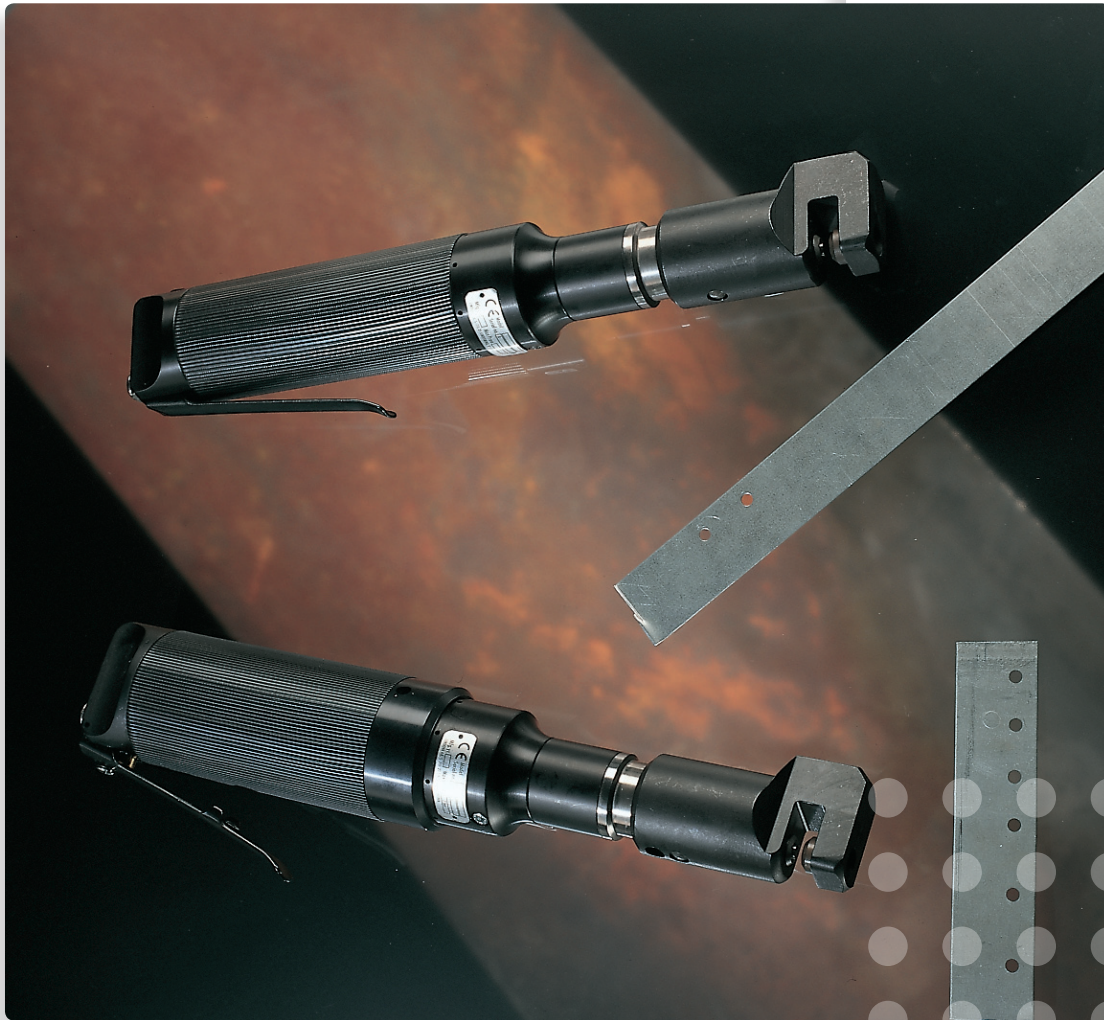

Air hydraulic punch tool for steel plate up to 3.5 mm

Lindova H4 is an air hydraulic hole punching tool. The design allows the user to work using rapid strokes and considerable force. The hole is burr-free.

The tool is both light weight and well-balanced to minimize the strain on the user. The air hydraulics also mean that the tool runs silently and is completely vibration-free.

The tool has few moving parts and has an extremely high level of operational reliability. And because we both design and manufacture the H4 Hole Punch ourselves, we can guarantee both a complete stock of spare parts and rapid service when required.

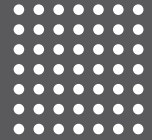

HOLE PUNCH LINDOVA H4

SEE OUR ENTIRE PRODUCT RANGE AT: WWW.LINDOVA.SE

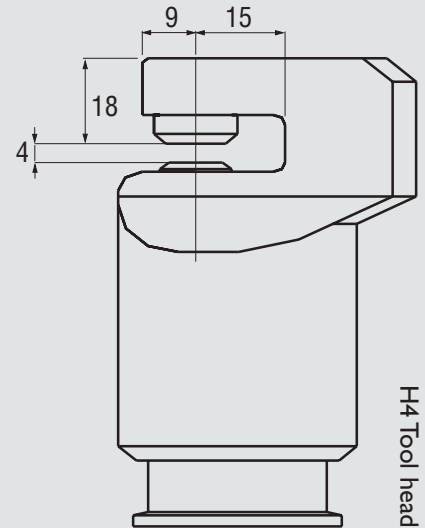

MODEL

Designation	Weight	Punch pressure*	Length	Ø Cylinder
H4/d-D333	1.8 kg	10 kN	334 mm	52 mm
H4/d-D433	2.0 kg	15 kN	351 mm	60 mm

d = Ø Punch

CAPACITY* (plate thickness mm)

Material	D333			D433		
	Aluminium	Steel (1311)	Stainless	Aluminium	Steel (1311)	Stainless
Punch Ø 4 mm	3.3	2.4	1.4	3.5	3.5	2.1
Punch Ø 5 mm	2.6	1.8	1.1	3.5	2.8	1.7
Punch Ø 6 mm	2.2	1.5	0.9	3.3	2.3	1.4
Punch Ø 7 mm	1.9	1.3	0.8	2.8	2.0	1.2
Punch Ø 8 mm	1.6	1.1	0.7	2.5	1.7	1.0

The Lindova H4 is supplied as a standard model with a choice of punch sizes between 4 and 8 mm. Special models offer punches at 0.1 mm intervals. Punch and pad are easily interchangeable.

Vibration level: < 2.5 m/s² 

Noise level: 63 dB (A)

* At 6 bar (90 Psi) pressure