

SETTING TOOL XT20

SEE OUR ENTIRE PRODUCT RANGE AT: WWW.LINDOVA.SE



Blind rivet nut setting tool

Lindova XT20 is a professional air hydraulic tool for setting blind rivet nuts.

The tool is easy to operate and combine all the features needed to guarantee fast, reliable assembly. The design incorporates tried and tested pneumatic engineering technology. The result is a highly practical tool for demanding production environments.

Setting blind rivet nuts is simply done controlled by one trigger. Threading off is done automatically. The stroke is easily adjusted to provide the optimum degree of heading, providing the joint with the required strength.

The unique design provides a tool that is well-balanced and easy to handle, minimizing strain on the operator.

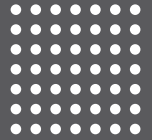

SETTING TOOL XT20

SEE OUR ENTIRE PRODUCT RANGE AT: WWW.LINDOVA.SE

TECHNICAL DATA XT20

Working pressure	5.5 - 7 bar
Pull Force (at 6 bar)	10 kN
Stroke	0-4 mm
Cycle time	< 2.5 sec
Noise level	< 75 dB (A)
Delivered equipped for	M4, M5, M6
Weight	1.7 kg
Height	150 mm
Length	220 mm

BLIND RIVER NUT

Material	M3	M4	M5	M6	M8	M10	M12	M14
Steel	X	X	X	X				
Aluminum	X	X	X	X	X			
Stainless steel	X	X	X					

X = Recommended working range

O = Useful working range is greater than recommended range

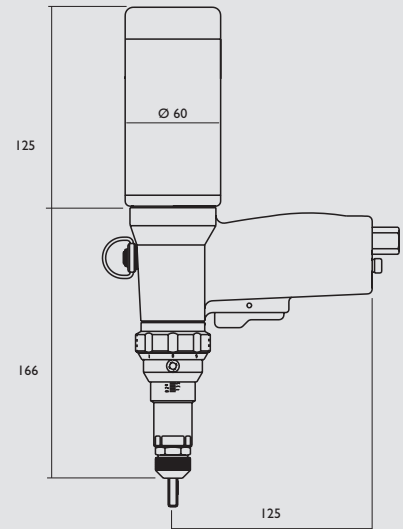

There are several XT models in the range, designed to accommodate most rivet nut sizes and materials (see table).

XT20 is the lightweight model designed for smaller rivets.

XT80/XT80S is the standard model covering a wide range of applications.

XT90 is designed for heavy-duty applications such as M10 and M12 Stainless steel.