

FOLDING AND HOLE PUNCHING TOOL

LINDOVA FH2

Pneumatic combination tool for lap folding steel plate.

Lindova FH2 is an air hydraulic folding and hole punching tool. The design allows the user to work using rapid strokes and considerable force.

FH2 is designed for use in lap folding steel plate. The head can be turned through 360°, which makes access easy with the tool. The tool can be supplied with a Ø5 mm or Ø6 mm punch.

The tool is both light weight and well-balanced to minimize the strain on the user. The air hydraulics also mean that the tool runs silently and is completely vibration-free.

The tool has few moving parts and has an extremely high level of operational reliability. And because we both design and manufacture the FH2 Folding and Hole Punching Tool ourselves, we can guarantee both a complete stock of spare parts and rapid service when required.



FH2

Designation	FH2/5-D227	FH2/6-D227
-------------	------------	------------

Punch Ø	5 mm	6 mm
Weight	1.1 kg	1.1 kg
Length	200 mm	200 mm
Cylinder Ø	52 mm	52 mm
Art. no.	8450-5	8450-6

Vibration level: < 2.5 m/s²

Noise level: 63 dB (A)

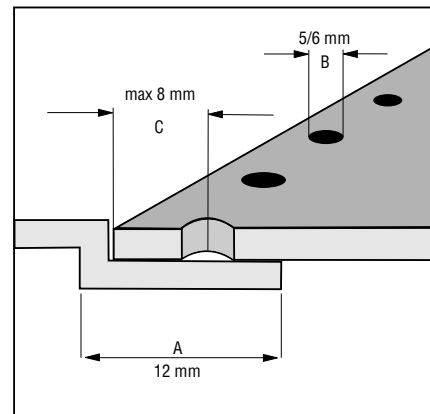

Postal address:
Lindova AB, Box 39, 711 21 Lindesberg, Sweden
Office: **Stafettgatan 1, Lindesberg, Sweden**
Tel: + 46 581 886 50 Fax: + 46 581 886 59
Web site: www.lindova.se
E-mail: info@lindova.se